

NPE Series

KD **navien**[®]

NPE-A and NPE-S Condensing Tankless Water Heaters

Navien makes
it easy to
go tankless in
residential and
commercial
applications.



New NaviLink Wi-Fi remote
control system...Now available
as an add-on accessory.



T H E L E A D E R I N C O N D E N S I N G T E C H N O L O G Y

NPE-Advanced

Our advanced high efficiency condensing tankless water heater technology with the only internal pump and buffer tank

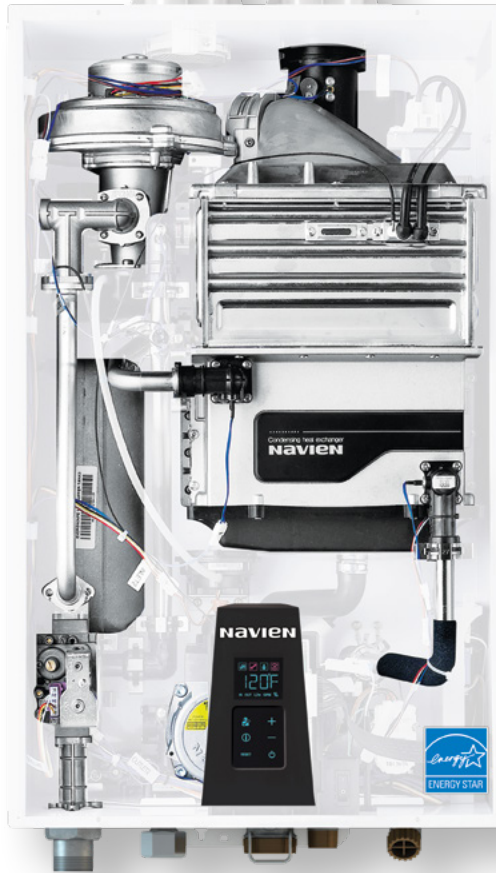

2" PVC VENTING
UP TO 60 FT

1/2" GAS CAPABILITY
UP TO 24 FT

CASCADE UP TO 16 UNITS

ComfortFlow[®]

Exclusive built-in recirculation system included on all NPE-A models

Navien ComfortFlow[®] was the first system to incorporate a built-in insulated buffer tank and recirculation pump. The buffer tank eliminates the "cold water sandwich" effect and issues of minimum flow rates commonly found in other tankless water heaters. The recirculation pump saves on water bills by reducing the time to get hot water. When activated, the optional ComfortFlow mode results in additional energy usage.

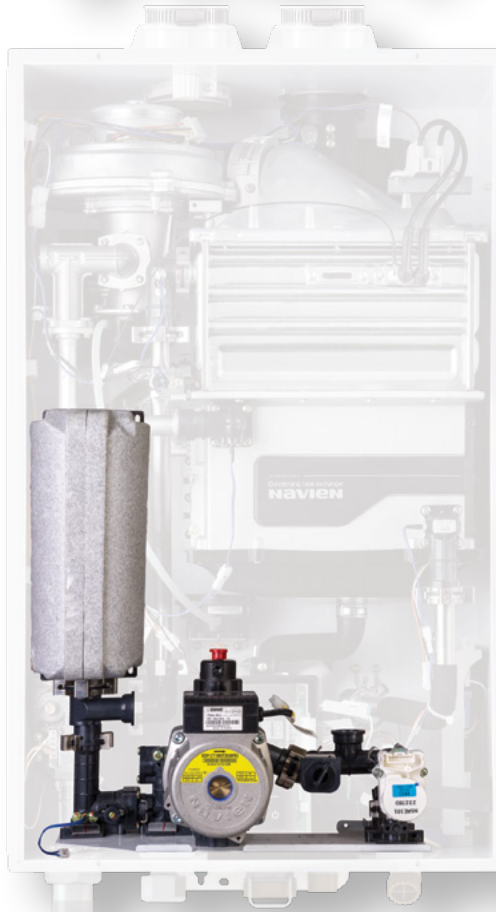

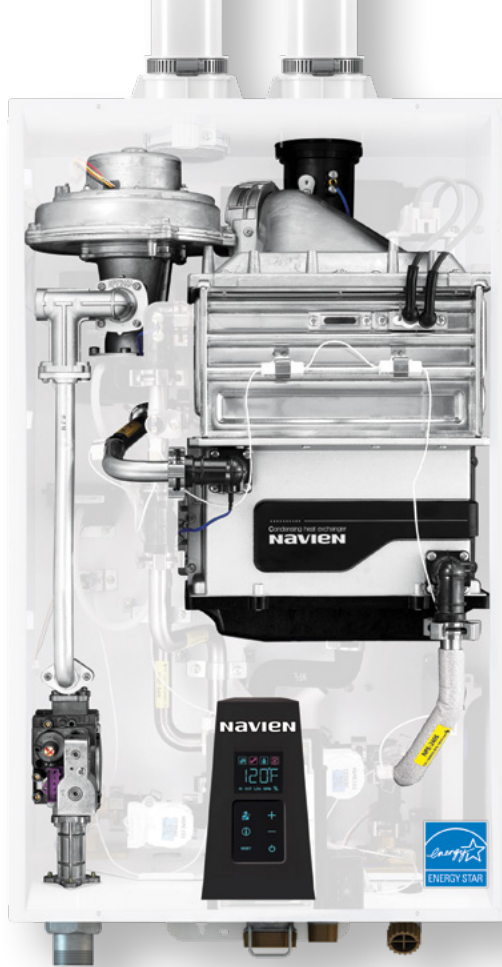

DUAL STAINLESS
STEEL
HEAT EXCHANGERS

NG^{OR} LP FIELD GAS
CONVERTIBLE

RESIDENTIAL &
COMMERCIAL

NPE-Standard

Our standard ultra condensing tankless technology with the industry's top rated unit for energy efficiency



NPE-A and NPE-S series facts

Temperature rise

Temp rise (°F)	150S GPM	180 series GPM	210 series GPM	240 series GPM
35	6.8	8.4	10.1	11.2
40	5.9	7.4	8.8	9.8
45	5.3	6.5	7.8	8.7
50	4.8	5.9	7.1	7.8
55	4.3	5.3	6.4	7.1
60	4.0	4.9	5.9	6.5
65	3.7	4.5	5.4	6.0
70	3.4	4.2	5.0	5.6
75	3.2	3.9	4.7	5.2
80	3.0	3.7	4.4	4.9
85	2.8	3.5	4.2	4.6
90	2.6	3.3	3.9	4.4
100	2.4	2.9	3.5	3.9
110	2.2	2.7	3.2	3.6
120	2.0	2.5	2.9	3.3
130	1.8	2.3	2.7	3.0
140	1.7	2.1	2.5	2.8

DHW capacity

Models	Natural gas (BTU/H)	Propane gas (BTU/H)
NPE-150S	18,000–120,000	18,000–120,000
NPE-180 A/S series	15,000–150,000	15,000–150,000
NPE-210 A/S series	19,900–180,000	19,900–180,000
NPE-240 A/S series	19,900–199,900	19,900–199,900

Operating cost

Navien tankless	175 therms	\$191*
Other tankless	209 therms	\$228*
Standard tank	269 therms	\$293*

*Based on Energy Guide cost estimates using \$1.09 per therm of natural gas. Cost is in US dollars.

U.S. Green Building Council LEED Points

Water heater	Location	Recirculation
1 Point	2 Points	3 Points

Warranty

Application		Labor	Parts	Heat exchanger
Residential	Standard or controlled recirculation	1 year	5 years	15 years
	Uncontrolled recirculation	1 year	3 years	5 years
Commercial or Combi ¹	Standard or controlled recirculation for units produced on or after Jan. 1, 2016	1 year	5 years	8 years
	Standard or controlled recirculation for units produced before Jan. 1, 2016	1 year	3 years	10 years
	Uncontrolled recirculation ²	1 year	3 years	3 years

¹Combi refers to a combination potable water and space heating application. Water heaters cannot be used in space heating only applications.

For complete details please refer to the full warranty at NavienInc.com.

Lower HERS home index score



THE LEADER IN CONDENSING TECHNOLOGY

NPE-Standard

When it comes to water heater performance...
it's all about the output

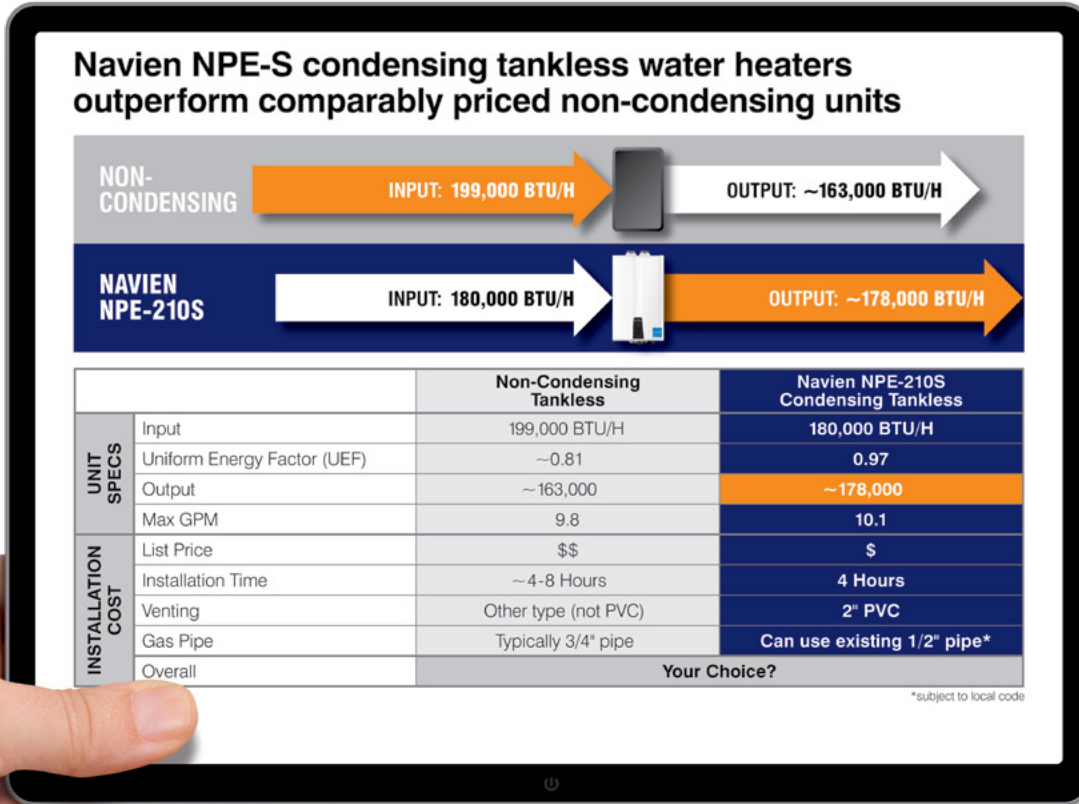

The NPE-S condensing tankless water heaters are so efficient that they outperform much larger capacity non-condensing competitors. More output for the money, lower installation costs and lower operating costs for customers makes it a smart choice.



Cascade up to 16 units

With Navien cascading technology, when a unit gets up to 75% capacity the next unit will turn on to help meet requirements. This flow and demand ratio will continue until all 16 units are generating hot water as needed. The Navien cascading system also balances out the workload of each unit for longer life.

Common vent up to 8 units

Building penetrations are reduced with Navien's common venting feature.



World-class quality

The global leader in energy efficient technology

KD Navien was an early leader in developing condensing technology for boilers and water heaters. Condensing technology maximizes energy savings by capturing additional heat from the flue gases. As a result, energy consumption and greenhouse gases are significantly reduced.

Easy to sell, easy to install

Cuts installation time in half

Thanks to using ½" gas pipe (subject to local code) and 2" PVC venting, you can install a Navien tankless water heater in about half the time as competitive tankless heaters.

Fewer callbacks, longer life, faster heating

Navien was first to offer dual stainless steel heat exchangers, rather than copper, which extends the life of the unit by resisting corrosion.

Energy Star highest rated gas water heater

The NPE is the most energy efficient* tankless water heater in the industry. Our condensing technology delivers performance up to 0.97 UEF/0.99 EF.

*EPA Energy Star Directory.



Brian Palm, Director of Sustainability and an environmental science teacher said, "Our tank system was more than 10 years old and from an efficiency perspective, we had some potential for savings." He calculates the new Navien system will save the school \$20,000 a year.



Contractors recommend Navien for its stainless steel heat exchanger. "It will last a lot longer than copper heat exchangers on other tankless units."

J. Richards

KD NAVIEN®

T H E L E A D E R I N C O N D E N S I N G T E C H N O L O G Y

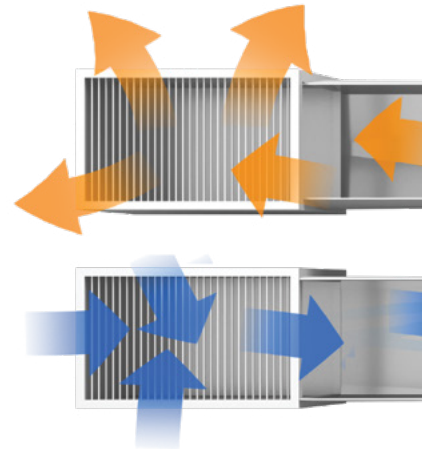

HotButton™

NPE-A on-demand recirculation accessory



At the push of a button, the Navien HotButton activates the internal recirculation pump and gas fired burner to heat up the water in the supply lines.

This gives your customers hot water when they need it, saving water and money. This add-on accessory is available on all NPE-A series tankless water heater models, and is California Title 24 compliant.

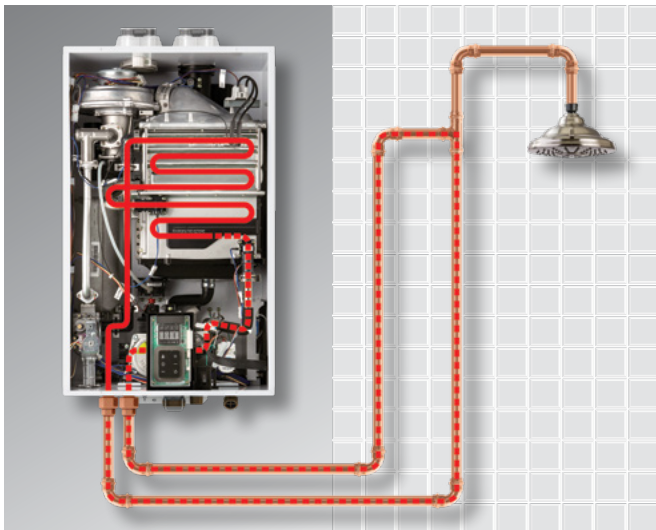

NaviLink™

NPE-A&S optional Wi-Fi remote control system

This add-on accessory will enable customers with smartphones and tablets to control temperatures remotely, access usage data and receive diagnostic notifications on all Navien products (NPE-A, NPE-S, NCB-E, NFC, NHB, NFB). Existing installations/stock may require the purchase of a new main PCB and front control panel.



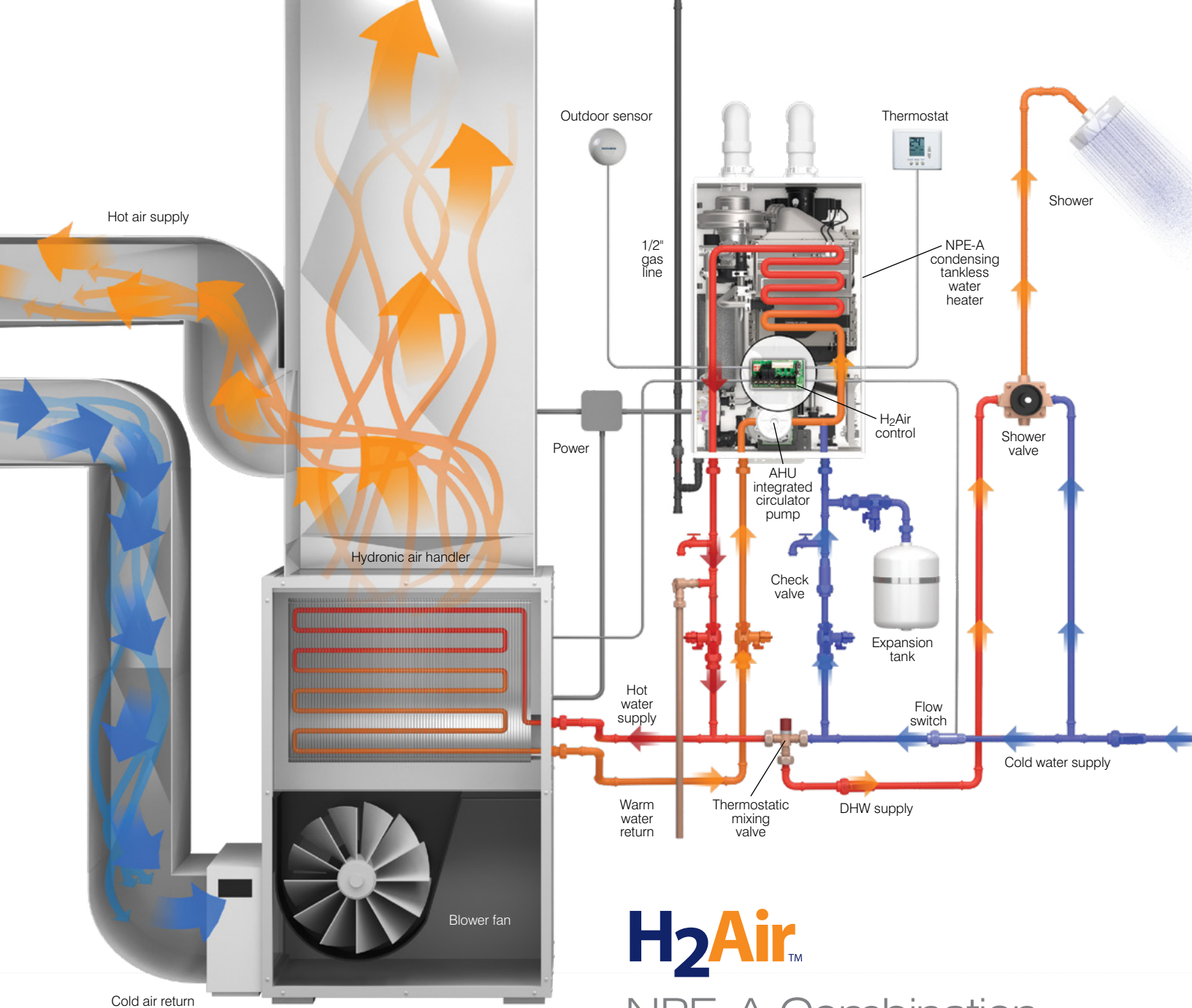

H₂Air™

NPE-A Combination space heating and DHW

H₂Air is compatible with hydronic air handler models that require W1/W2/R terminals along with single or dual-stage thermostats.**

*Compatible with NPE-A series units produced on or after May 31, 2014.

**Self-powered thermostats only.

The H₂Air Kit utilizes the NPE-A pump to circulate the hot water for the hydronic air handler. This removes the need to purchase an additional circulator for the heating system.

Designed for both retrofit and new construction residential applications, Navien's H₂Air Kit* consists of an add-on controller that allows for space heating and DHW system integration between NPE-A series tankless water heater models and a hydronic air handler.



Dimensions

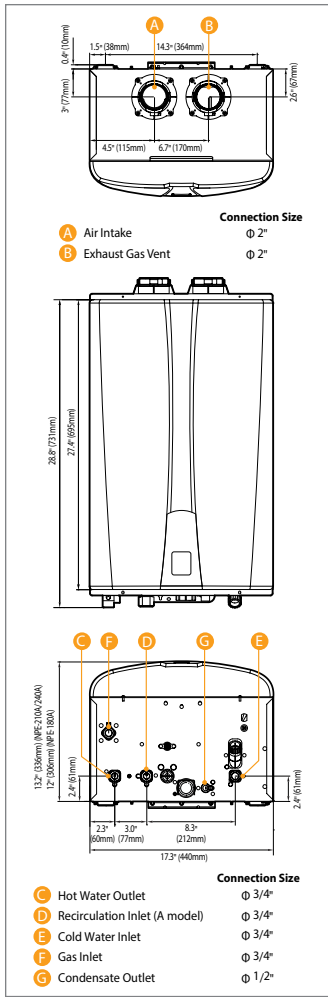

Specifications

Item	Model						
	NPE-150S	NPE-180A	NPE-180S	NPE-210A	NPE-210S	NPE-240A	NPE-240S
Heat capacity (input)	Natural gas	18,000–120,000 BTU/H		19,900–180,000 BTU/H		19,900–199,900 BTU/H	
	Propane gas						
Efficiency ratings	UEF (NG & LP)	0.96	0.96	0.96	0.97	0.96	0.97
	EF (Canada NG & LP)	0.97	0.97	0.99	0.97	0.99	0.99
Flow rate (DHW)	35°F (19°C) temp rise	6.8 GPM (26 L/m)	8.4 GPM (32 L/m)		10.1 GPM (38 L/m)		11.2 GPM (42 L/m)
	45°F (25°C) temp rise	5.3 GPM (20 L/m)	6.5 GPM (25 L/m)		7.8 GPM (30 L/m)		8.7 GPM (33 L/m)
	67°F (36°C) temp rise	3.2 GPM (12 L/m)	4.3 GPM (16 L/m)	4.2 GPM (16 L/m)	5.0 GPM (19 L/m)	5.2 GPM (20 L/m)	5.6 GPM (21 L/m) / 5.7 GPM (22 L/m)
Dimensions	17.3"W x 27.4"H x 13.2"D						
Weight	55lbs (25kg)	75lbs (34kg)	67lbs (30kg)	82lbs (37kg)	75lbs (34kg)	82lbs (37kg)	75lbs (34kg)
Installation type	Indoor or outdoor wall-hung						
Venting type	Forced draft direct vent						
Ignition	Electronic ignition						
Water pressure	15–150 PSI						
Natural gas supply pressure (from source)	3.5"–10.5" WC						
Propane gas supply pressure (from source)	8"–13" WC						
Natural gas manifold pressure (min-max)	-0.04" WC to -0.38" WC	-0.04" WC to -0.84" WC		-0.05" WC to -0.36" WC		-0.05" WC to -0.58" WC	
Propane gas manifold pressure (min-max)	-0.04" WC to -0.42" WC	-0.05" WC to -0.50" WC		-0.10" WC to -0.66" WC		-0.10" WC to -0.78" WC	
Minimum flow rate	0.5 GPM (1.9 L/m), < 0.01 GPM (0.04 L/m) option for "A" models*						
Connection sizes	Cold water inlet	3/4" NPT					
	Hot water outlet	3/4" NPT					
	Gas inlet	3/4" NPT					
Power supply	Main supply	120V AC, 60 Hz					
	Maximum power consumption	200W (max 2A), 350W (max 4A) with external pump connected					
Materials	Casing	Cold rolled carbon steel					
	Heat exchangers	Primary heat exchangers: stainless steel, secondary heat exchangers: stainless steel					
Venting	Exhaust	2" or 3" PVC, CPVC, PP, SS / 2" or 3" special gas vent type BH (Class II, A/B/C)					
	Intake	2" or 3" PVC, CPVC, PP, SS / 2" or 3" special gas vent type BH (Class II, A/B/C)					
	Vent clearances	0" to combustibles					
Safety devices	Flame rod, APS, ignition operation detector, water temperature high limit switch, exhaust temperature high limit sensor, power surge fuse						

*Available for "A" models configured in an optional ComfortFlow recirculation mode. Additional energy use will occur when using recirculation. Navien reserves the right to change specifications at any time without prior notice. Please refer to www.NavienInc.com to verify you have the most current information.

Accessories



NPE-BR002-1907
©2019 Navien Inc.

Navien Inc.
20 Goodyear, Irvine, CA 92618
800-519-8794, NavienInc.com



THE LEADER IN CONDENSING TECHNOLOGY